

**THE RIGHT CHOICE FOR  
YOUR MINING OPERATIONS**

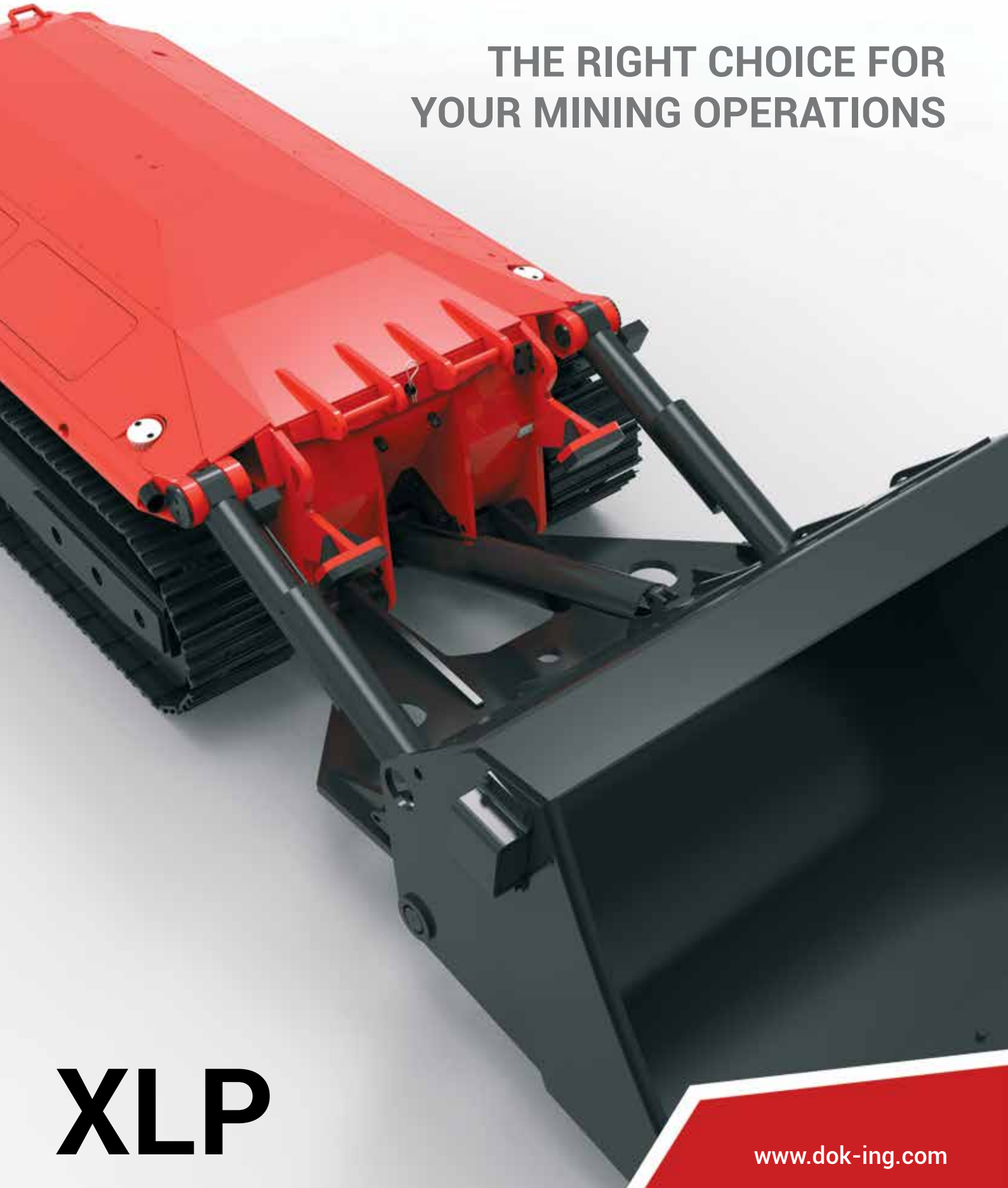

**XLP**

# Program mission

Independent of its size, DOK-ING mining equipment is known for its exceptional performance, excellent reliability, simple operation, operator comfort and easy serviceability.

The DOKING mining product line includes two different platform models, powered by diesel engines or electric motors, with five different tool attachments. The purpose of XLP equipment is creation of safe mining conditions. XLP platform is used for safe cleaning of production panels. XLP platform pushes the ore into the advance strike gully where the ore is collected and transported to the conveyer system. XLP platform is also used for sweeping and vamping activities resulting in manual stope-cleaning labor being largely eliminated. XLP platform is controlled by a single operator using a simple hand held radio remote control unit.



## CORE BENEFITS

- Single operator
- Equipment monitoring and data logging
- Improved working conditions and safety
- Increased production (Increased saturation of mined ore per total tonnage hauled up to the surface - getting more of your final produce while spending the same amount of time)
- Low operating cost



# XLP platform at glance

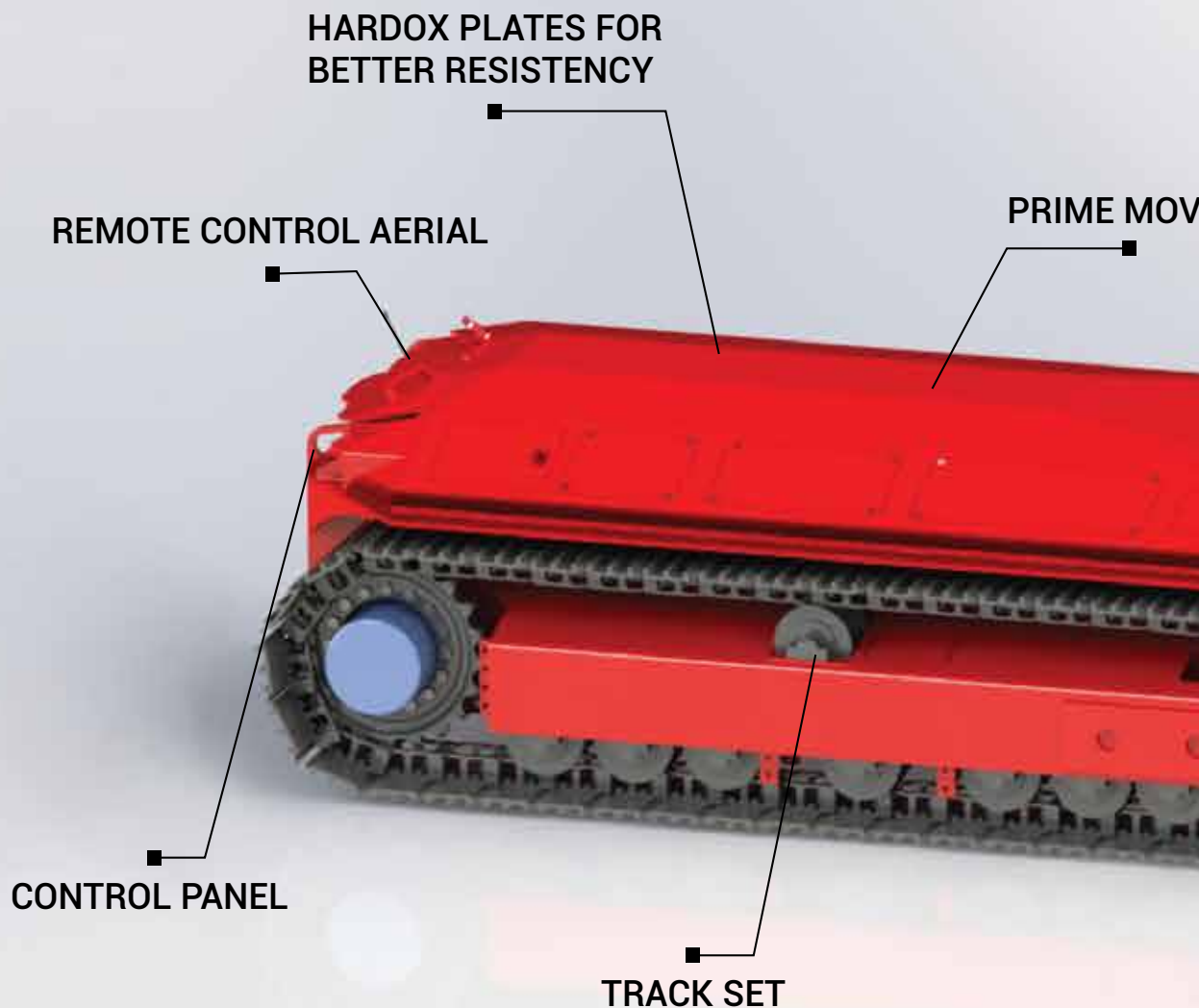

## MACHINE DESIGN

The XLP platform design can withstand the most severe underground working conditions. It has the ability to work in high temperatures and conforms to the required safety systems to protect the operator and personnel in the vicinity of the operation. The XLP platform has the ability to work in gradients of up to 30 degrees and at mine heights from 1.2 m to 1.6 m which makes it suitable for mining a large proportion of reef types in various mining industries (platinum, gold, diamonds etc.). Miners work far below the earth's surface and have little time and less space to deal with unscheduled breakdowns. With reliable and robust machine such as XLP productivity is paramount, especially when downtime costs are decreased by using mechanical equipment to clear out ore and increase safety.

ER

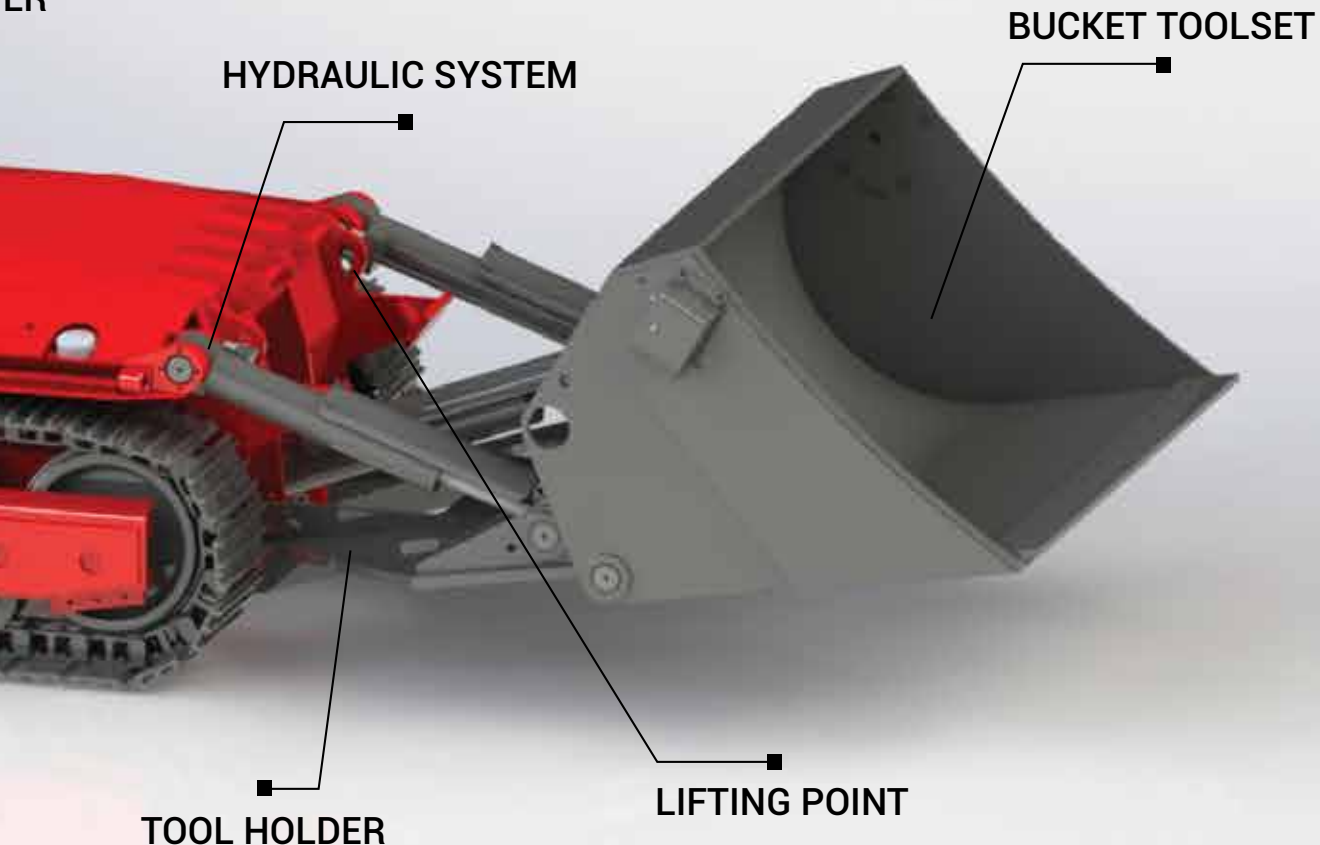

## MACHINE MANEUVERABILITY

Being relatively light and small in size, the XLP platform can navigate throughout various obstacles, when moving either in parallel or perpetual direction. Low center of gravity and powerful engine enables operating on steep slopes managing up to 30° uphill and downhill. It is designed to negotiate and overcome difficult undulations and changes in mining panels that can be typically found in underground mines. The system can autonomously free itself when stuck by lifting and pushing hydraulics connected to the tool attachments which can be extended, lifted or lowered.

# Tools

XLP platform tool attachments are designed to deliver exceptional dependability, reliability and productivity for your operations. They are designed specifically to fit underground environment, with easy maintenance access and extended service intervals. Our priority is to make sure that every tool meets or exceeds the world's toughest standards, to keep your operation as clean, and your cost per ton as low, as possible.

Tools are:

- Bucket
- Blade
- Sweeper
- Ejector bucket
- Gripper

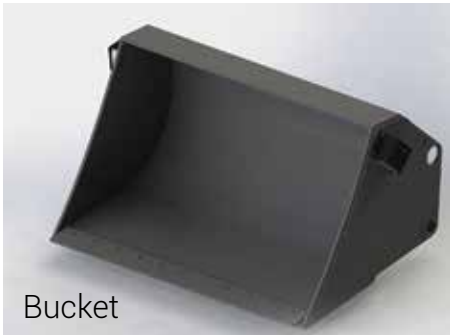

Bucket



Blade

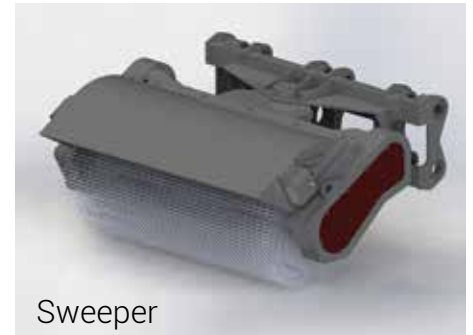

Sweeper

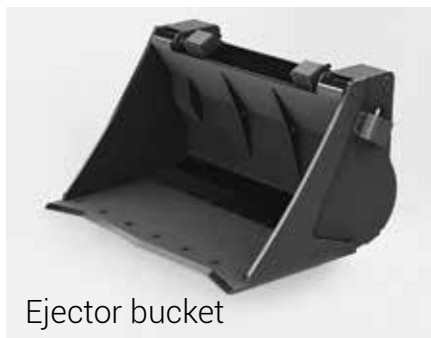

Ejector bucket



Gripper



## AREAS OF APPLICATION:

- Underground mines with narrow reef
- Room and pillar mining
- Cleaning under conveyor belts
- Long hole drilling mining set up
- Accelerated bridge construction
- Cleaning under smelters and refining plants

**XLPD TECHNICAL CHARACTERISTICS**

Dimensions (L x W x H)	
Prime mover	2700 x 1380 x 834 mm
Prime mover with blade	3435 x 1436 x 834 mm
Prime mover with bucket	4391 x 1632 x 834 mm
Prime mover with sweeper	4237 x 1652 x 834 mm
XLPD Clearance	
Ground clearance	130 mm
Weight	
XLP with dozer blade	4000 kg
XLP with bucket	4300 kg
XLP with sweeper	3820 kg
Prime mover separately	3500 kg
Blade tool	500 kg
Bucket tool	800 kg
Sweeper tool	320 kg
Engine	
Engine designation	DEUTZ DIESEL 3100 ccm, 4 cylinder
Power rating	88 HP at 2800 RPM
Direction of rotation	Clockwise
Electrical system	24 V
Torque	260 Nm at 1500 rpm
Engine Weight	257 kg (dry)/270 kg (wet)
Oil	12 l
Fuel capacity	60 liters
Fuel consumption	6 - 12 liters/hour
Power transmission	
Hydraulic oil	110 liters
Propulsion	Hydrostatic
Track gearbox oil	2 x 0,6 l
Drive train	Track driven
Travelling speed	0 - 5 km/h
Working speed	0.3 - 1.2 km/h
Others	
Productivity	50 - 120 t/h
Chassis	20 mm steel plate
Data communication	FSK - 433 MHz
Lights	LED technology

